



INTELLIPACK™

Packaging Technology for Smart Business



Foam-In-Place Packaging

Just Got Smarter



The Only Foam-In-Place Packaging Partner You Will Ever Need

IntelliPack understands the packaging performance pressures and economic concerns facing manufacturing operations. That's why we've pioneered the industry's most advanced foam-in-place systems to help our customers maximize packaging productivity - and do it economically.

We call this advancement smart packaging for the technologies that power the SmartBAGGER machine and SmartAIM handheld dispenser.

Each system incorporates reliable, easy operation with ergonomic design and leading edge technology. The result? Foam-in-place packaging solutions so smart they minimize operator interaction and virtually eliminate unexpected downtime.



INTERNET CONNECTION MONITORS EQUIPMENT PERFORMANCE 24-HOURS A DAY, EVERY DAY

Reduce downtime

Track chemical and film consumption

Predict maintenance

Access system

There's More Behind IntelliPack Than You Think

When it comes to prompt, knowledgeable service, the experts at IntelliPack are dedicated to keeping your foam-in-place process operating at peak performance. With a depth of resources behind us, IntelliPack provides customers with:



- Custom package engineering
- Daily equipment monitoring
- Immediate service technician dispatch
- Nationwide network of distribution centers
- Equipment integration into product line
- Free installation by factory-trained representatives
- CE marked



Superior Technology Means Trouble-Free Operation

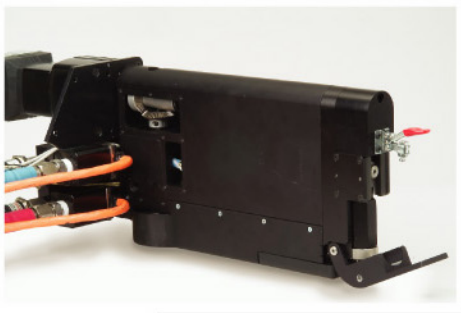

IntelliPack's team of design engineers combines practical problem solving with innovative discovery to develop easy-to-use foam-in-place solutions that deliver the outstanding performance our customers expect. We used the most sophisticated visualization tools and computerized intelligence to analyze and eliminate the expensive, inconvenient and time-consuming problems that plague foam-in-place operators on a daily basis.



Expedite troubleshooting

Reorder supplies online

variables

SmartSEAL™ Software Delivers Perfect Seal and Clean Cut, Every Time

- Controls seal wire and cut wire temperatures
- Extends wire life
- No warm-up time
- Eliminates carbon and foam build up on sealing jaws
- Minimizes service and downtime

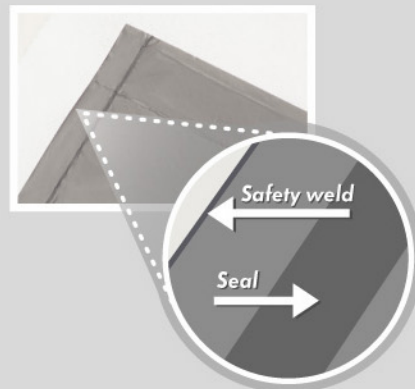



SmartBAGGER™
Machine

User-Friendly Controls

- Adjust machine height and screen angle in front of operator
- Help menu navigation similar to Web site
- Convenient, front location
- Large, easy-to-push buttons
- Programmable

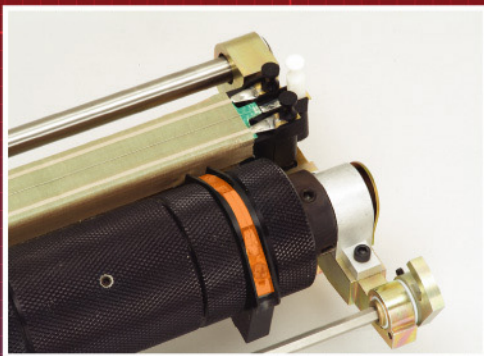

Easy-to-Replace Sealing Wires

- Plug-in design installs in five seconds
- Simple, quick access
- Advanced temperature-control software extends wire life
- Lifetime warranty



SmartSEAL Technology

Long-Lasting Mixing Module Reduces Downtime

- Most horsepower available
- 250,000-cycles/module
- Continuously replenished solvent supply
- Zero maintenance expense
- Lifetime warranty



SmartBAGGER™ & SmartAIM™

Ergonomic Design, User-Friendly Operation and Reliable Performance in Two Smart Packages



SmartAIM™
Handheld

Our design engineers developed the SmartBAGGER machine and SmartAIM handheld from the operator's point of view, with a focus on safety, ease of operation and die-hard performance.

The SmartBAGGER and SmartAIM features shown here are standard assemblies and may be customized to meet your specific requirements. Contact IntelliPack to learn how our Smart machines can optimize, energize and economize every inch of your foam-in-place packaging process.

1-866-692-2166 www.intellipack.com

Ergonomic Film Deployment

- Easy-to-thread film with quick access to nip rolls
- Roll locks into operating position and easily unlatches with the push of a button
- DC motor monitors film usage to adjust film tension and shut off machine when out of film

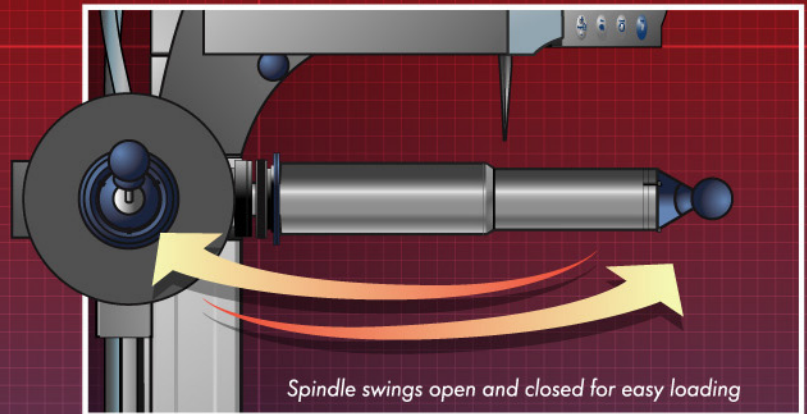

Adjustable Height

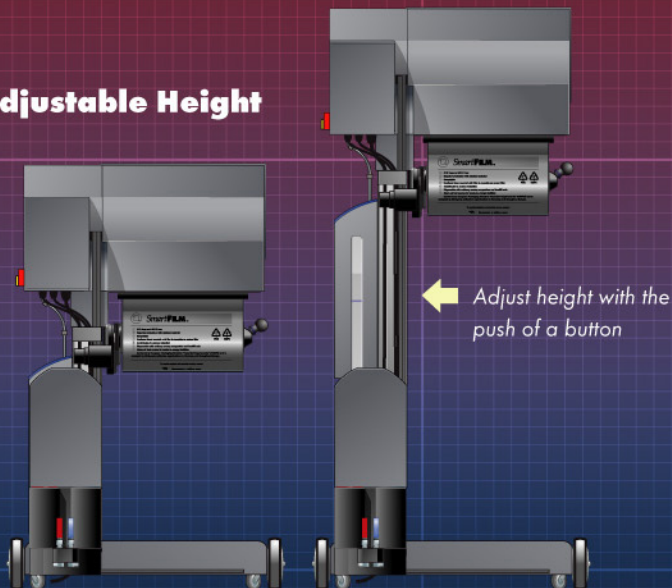

Sophisticated, Reliable, Maintenance-Free Tip Cleaning System

- Cleaning brush and drive mechanism provide powerful, rapid mechanical brushing
- Software monitors usage to automatically clean tip as needed throughout the day

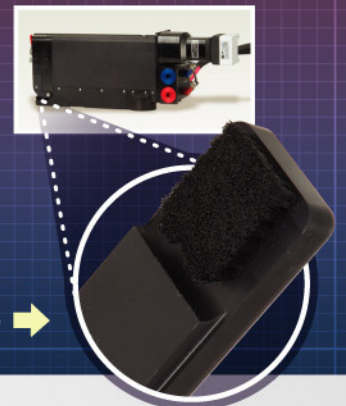

 **SmartFOAM™** A/B Chemical

| | 55-GALLON DRUMS | 275-GALLON TOTES |
|------------|-----------------|------------------|
| A chemical | 500 lb | 2,500 lb |
| B chemical | 450 lb | 2,300 lb |

| INTELLIPACK™ CHEMICAL SYSTEM | APPLICATION |
|------------------------------------|---|
| SLD | Super low-density foam provides average cushioning and material recovery. SLD is a high performance replacement for loose fill, Kraft paper, air bags, cellulose wadding or newspaper. |
| LD | Low-density foam molds to protect a wide range of light to medium weight products (10-50 lb). |
| HE | High-efficiency foam provides good, initial cushioning and fair protection after multiple drops for medium to heavy products (20-60 lb). HE is a preferred alternative for all flexible protective packaging. |
| MLD | Moldable foam provides flexible cushioning and excellent recovery for fragile or heavier products (40-120 lb) after multiple drops. MLD foam is an excellent replacement for all flexible protective packaging. Pads may be reused. |
| FLX | Flexible foam provides excellent recovery for medium to heavy products (50-150 lb), even after multiple drops. FLX foam is an excellent replacement for all flexible protective packaging. Pads may be reused. |
| BB | BB foam provides excellent blocking and bracing protection and more rigid void fill for heavy equipment (up to 300 lb) and molded or fabricated materials. |

Specialty foam systems may be formulated upon request.

IntelliPack Keep Produ

The SmartBAGGER machine and SmartAIM handheld equipment are specifically engineered to work with IntelliPack's SmartFOAM, SmartLUBE

 **SmartFILM™**



Centerfold
12-in. & 19-in.

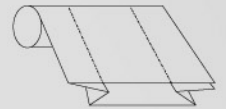

Gusseted
12-in. & 19-in.



2.5-gallon jug

16-ounce aerosol can



Supplies ction Online

and SmartFILM supplies. Our supplies and replacement parts offer exceptional advantages that translate into long-term value.



Custom Printing Available

SMART OPTIONS

Chemical Pump Options

- Lightweight pumps feature state-of-the-art brushless motors and controls to run 10-times longer
- No additional components required



Inline pump



Barrel pump



Multi-Drop Option

- Eliminate changeover downtime
- Conserve space
- Integrate multiple systems on one chemical supply



Call the supply, parts and service hotline at 1-866-692-2166, or program your Smart machine to order for you!

www.intellipack.com



1705 Wallace Drive, Ste. 112 Carrollton, TX 75006 1-866-692-2166 www.intellipack.com